

TONIC II

Corps à encastrer

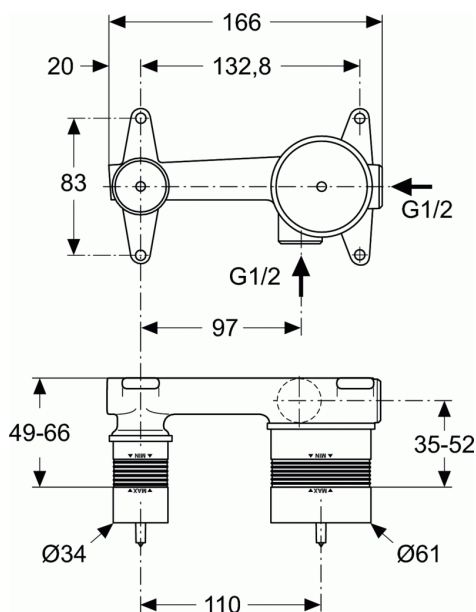
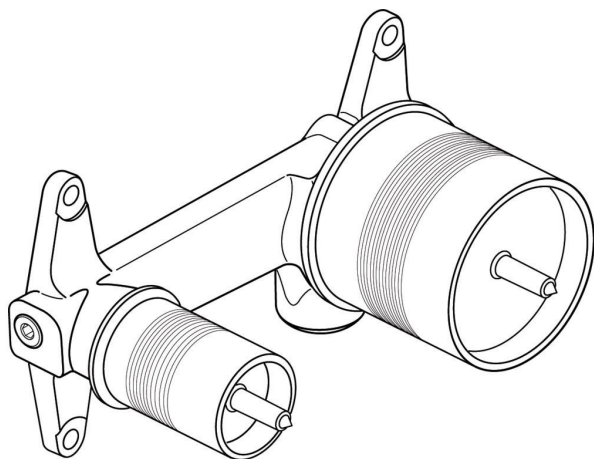

Corps à encastrer

FINITIONS*

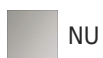

NU

* NU = Sans finition (NU)